

PA-25-XX-1800

Code	Rail Finish	Cap Finish
PA-25-ZN-1800	Stain Colour Hairline	Satin Nickel
PA-25-4Q4Q-1800	Dark Bronze	Dark Umber
PA-25-KGQ-1800	Blasted Black	Pearl Black
PA-25-LQLQ-1800	Shot Champagne Gold	Shot Champagne Gold
PA-25-3U4Q-1800	Satin Bronze	Dark Umber

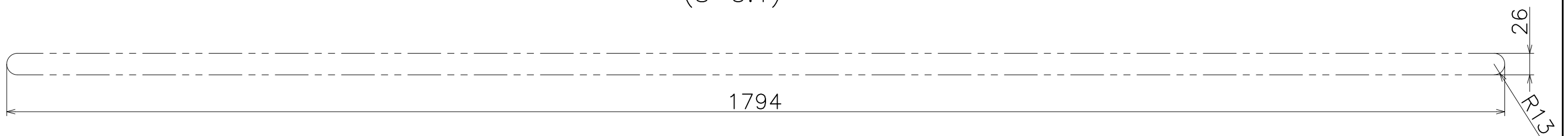
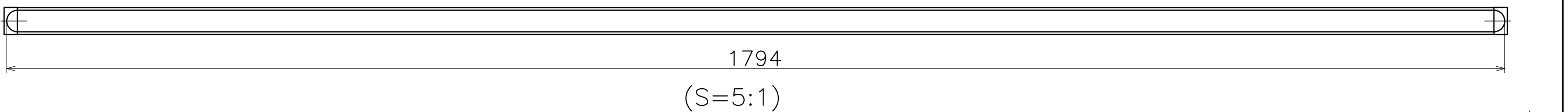
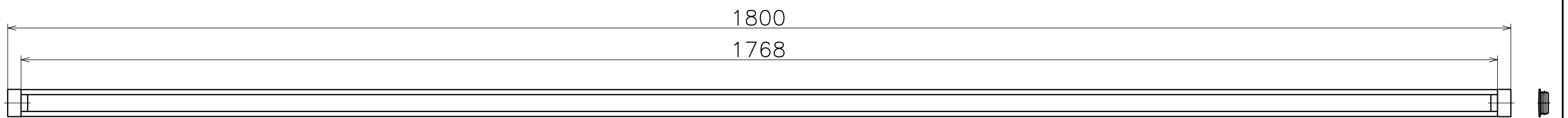
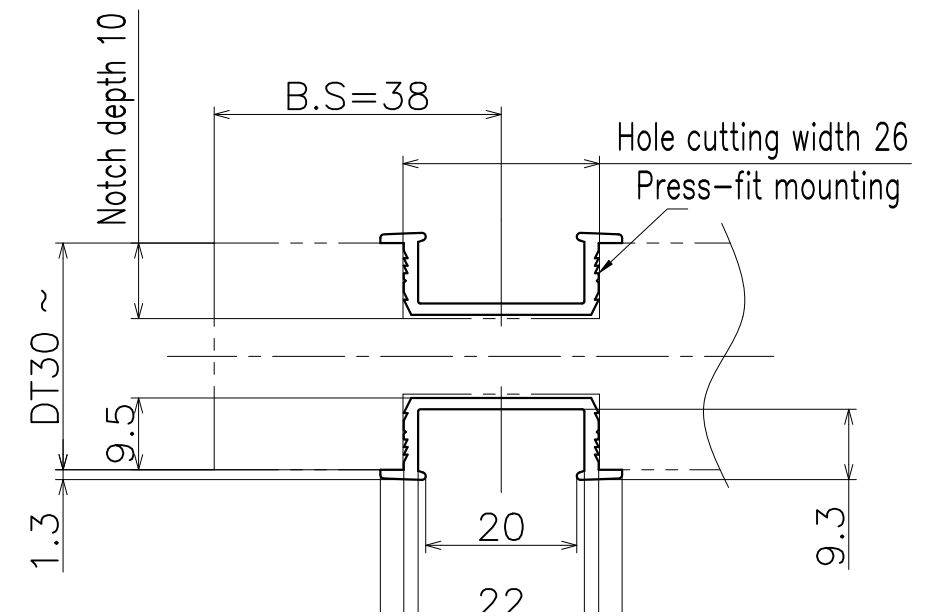
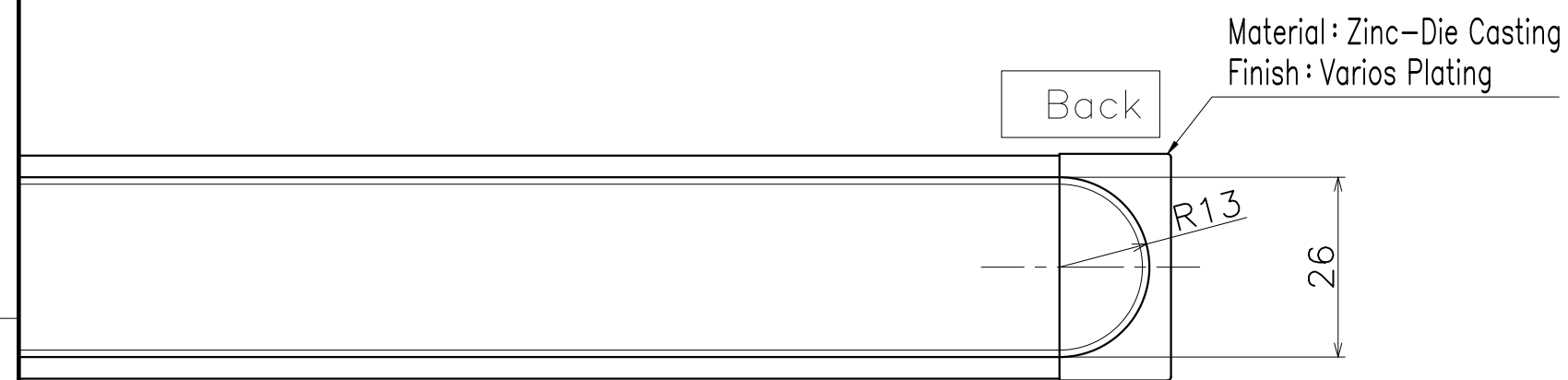
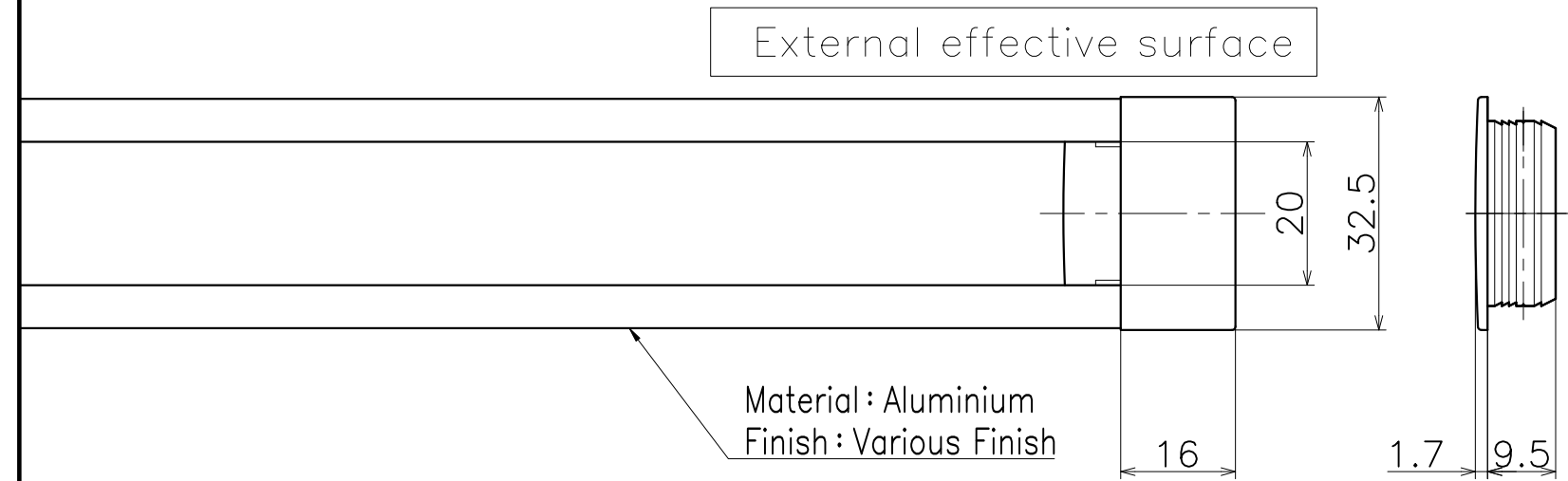

Cut-out drawing
(S=5:1)

KAWAJUN

河淳株式会社
2022/02/17